



**Unrivaled, Patented  
Cooling and Energy Solutions for**

**Mobile Power Generation Industry  
&  
Motor/Generator/Pump Manufacturers**

**Cool Technologies, Inc.  
December 2015 Investor Deck**



## ADDRESSABLE MARKET #1

### Mobile Generation

*(Global: \$100 billion\*\*)*



What happens when you engineer (and patent) Cool Tech's thermal technology and couple it with a revolutionary (PCT Patent Pending Unitized) Generator & Gearing system!

## **You create new onboard power that transforms any truck into a mobile generator**

- No more need to buy/rent or pull a big generator trailer
- Secret Sauce: Cool Tech's unitized generator & gearing system + Thermal IP
- Results in more power output, smaller unit, draws power from truck's engine or any other on board energy source
- Fully charge a Tesla in 20 minutes.... Anywhere. ( With Level III Charger)( MG200)

*\*\* Source: Hilty Moore & Associates, KMPG, 2014 Vehicle Technologies Market Report, US. Government; Chapter 3; Global Truck Sales, Statista*



## ADDRESSABLE MARKET #2

# Motors/Generators/Pumps

*(Global, combined: \$170 billion\*)*

The universal, daunting problem for machine manufacturers ... REMOVING HEAT.

- Heat affects anything that moves or generates power
- Heat degrades, warps or causes devices to fail outright



Cool Technologies was founded by prominent former GE, Siemens, Rockwell (others) engineers/managers to patent and commercialize a revolutionary “heat pipe” solution to “cool” a machine more effectively to:

- Significantly lower manufacturing costs
  - Up to 30%
- Increase Output (Via Liquid cooling effect, TEHPC)
  - Up to 40% more power density

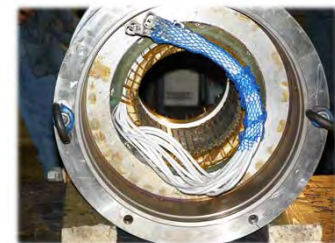

Photo of Cool Tech's in-machine heat pipe array and control system

\* Source: IEEE, NEMA, SWAPA, Hilty Moore & Associates, Emerson



## REVENUE MODEL

**Cool Tech is an IP & Engineering Company**  
(We work with our partners to manufacture the products utilizing their assets)

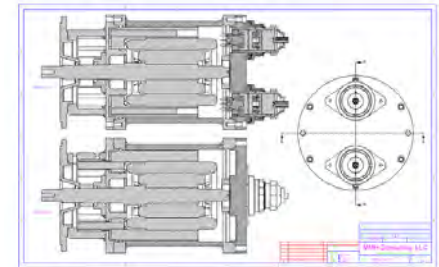

### **Motors / Generators**

- 2-3 year License Agreement – up front fee
- 3% Royalty on total sales price of motor or generator

### **Pumps**

- Joint Venture Product Markup

### **Mobile Generation**

- Joint Venture Product Markup – tremendous margins allow for extremely competitive pricing leverage



## INTELLECTUAL PROPERTY

- Cool Tech patent portfolio
  - Leverages a unique ability to increase power density and lower manufacturing costs in the motor/generator/pump (and other) industries
  - Modernized applications based on “heat pipes”
- Five U.S. utility patents issued
- 5+ Patent Cooperation Treaty (PCT) patents pending or applied for
- Patent Attorneys: Polster, Lieder, Woodruff & Lucchesi, L.C.

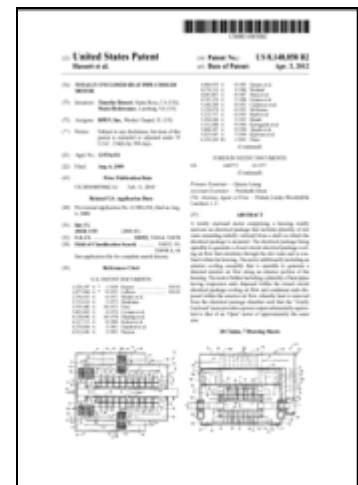
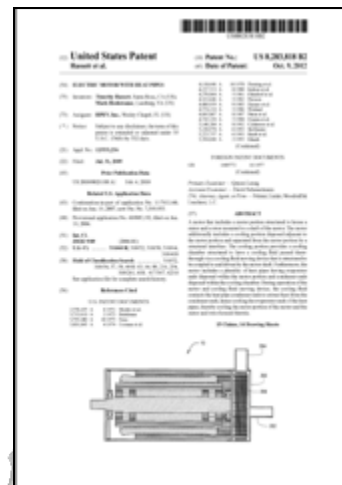
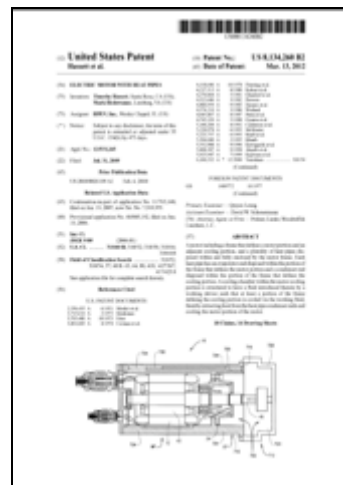
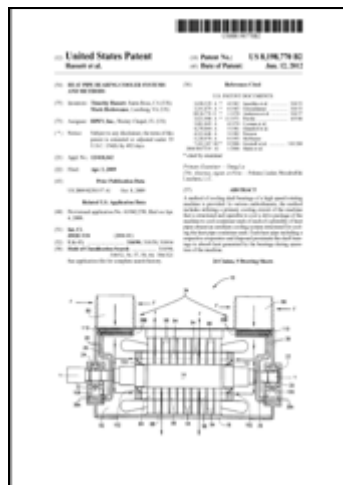



## Barriers to Entry – What the IP does

### Thermal dispersion technology

- When heat is removed from a motor or generator more effectively it puts out more horsepower or electricity – 25-40%
- ***Cool Tech has developed proprietary knowledge and design IP that utilizes heat pipe arrays remove heat from inside rotating equipment such as motors & generators***
- We design it into our OEM customer's motors or generators for them in one of two ways:
  - Redesign of the heat exchanger used on their motor/generator
    - Requires no capital commitment for the OEM
    - The OEM can put it into the marketplace in a matter of months
    - Improves ***Power Density*** by about 25% - 1000 hp motor now puts out 1250 hp
  - Design the thermal dispersion technology right into the motor or generator and remove the heat exchanger completely
    - Requires capital commitment from the OEM
    - Improves ***Power Density*** by as much as 40% - 1000 hp motor now puts out 1400 hp
- This also takes cost out by as much as 30% because the OEM can make a smaller motor with the same power output



## Barriers to Entry – What the IP does

Comparison of existing cooling technologies for motors & generators

	Fan Cooled	Water Cooled	Heat Exchanger	Cool Tech
Effective heat transfer coefficient	100W/m <sup>2</sup> K	1000 W/m <sup>2</sup> K	4000 W/m <sup>2</sup> K	<b>8000~9000 W/m<sup>2</sup>K</b>
Required Accessories	Blower/Fan & Piping	Pump & Piping	Pump, Radiator, Fan, Blower, Piping	<b>No pumps No moving parts</b>
Construction	Complex Attachments	Medium	Complex Attachments	<b>Simple</b>
Relative Cost (TCO)	Low	Medium-High	High	<b>Very Inexpensive</b>
Cost Effective Heat load	1000 W	2000 W	3000 W	<b>9000 W &gt;</b>
Reliability	Low (dust particles, filters required)	Medium	Low (fouling)	<b>High</b>

## Barriers to Entry – What the IP does

Heat Pipes – the foundation of the technology

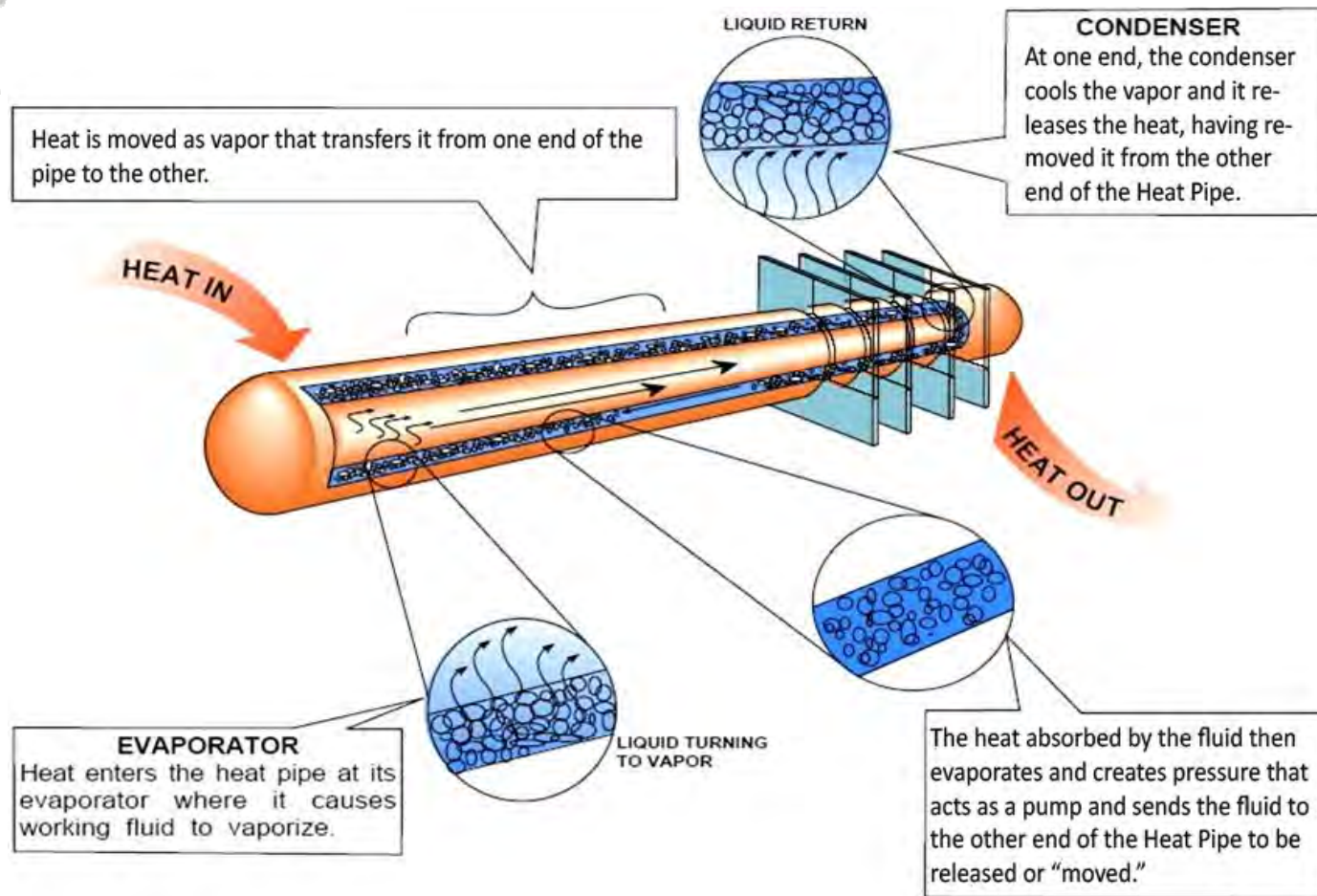





## Barriers to Entry – What the IP does

Heat Pipes – the foundation of the technology

Comparison of thermal conductivity:

- Copper: 380-401 W/m-K
- Aluminum: 160-237 W/m-K
- Cast Iron or Steel: 45-55 W/m-K

**Heat Pipes** – effective heat transfer rate BEYOND 1,000,000 W/m-K  
*(several thousand times that of copper)*

## Barriers to Entry – What the IP does

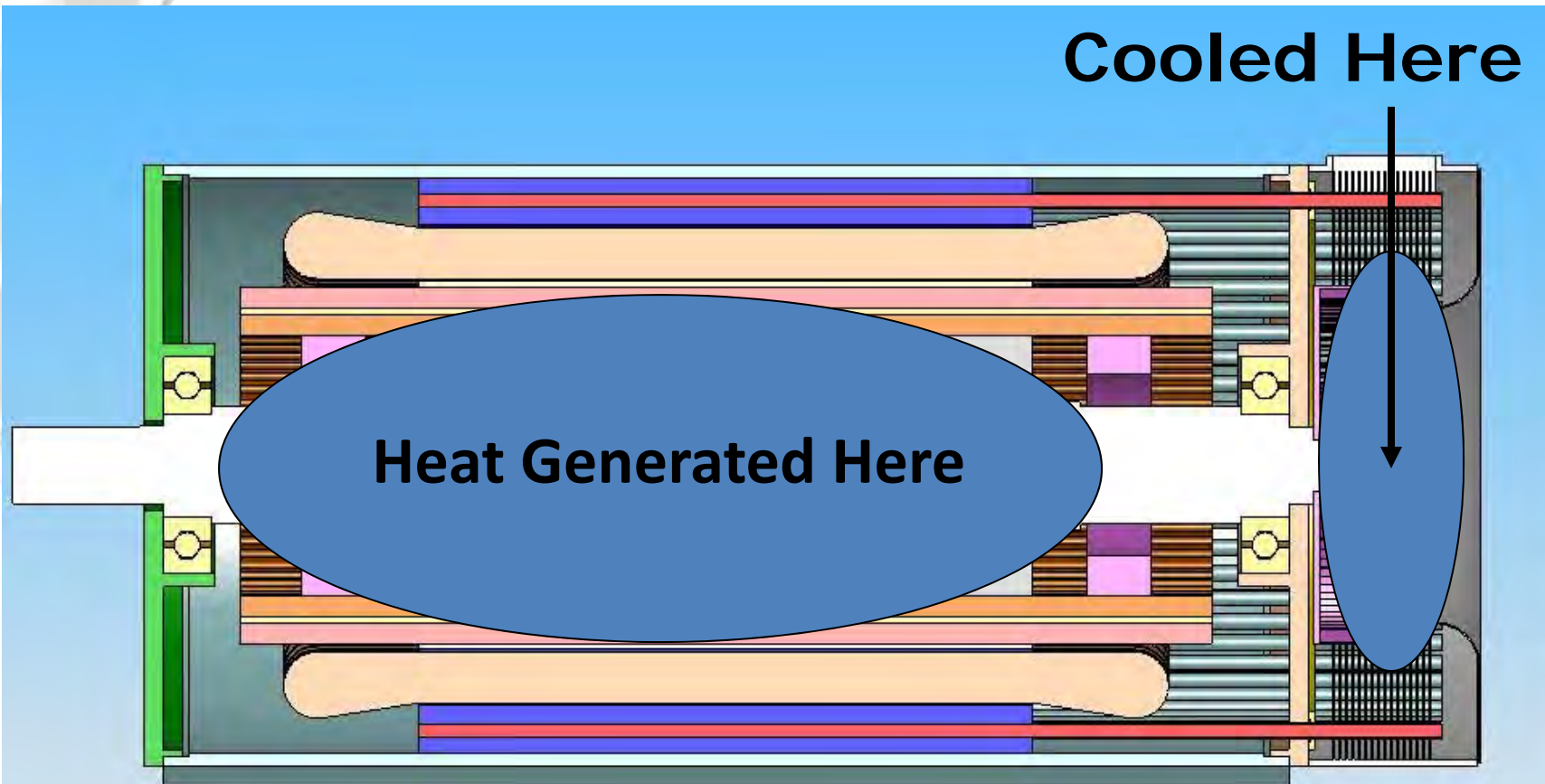

Heat is generated at the stator. From the stator, it is transferred to heat pipes. And from the heat pipes, it is transferred to the external heat exchanger which is cooled by air blowing over it.

## Barriers to Entry – What the IP does RVHP in the Rotor

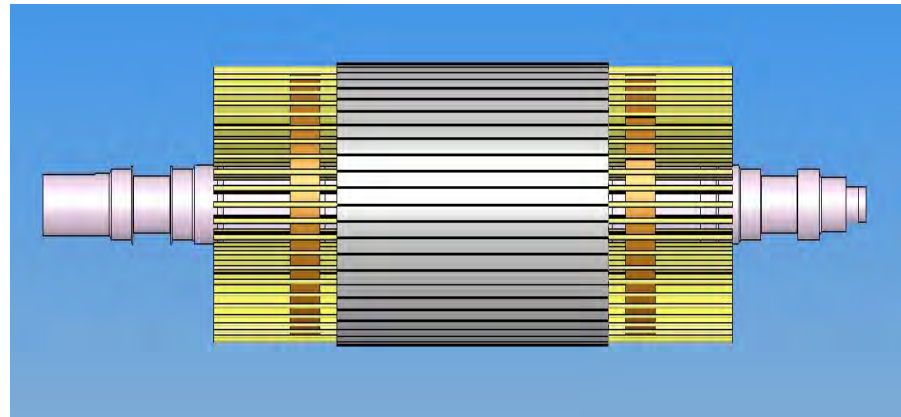
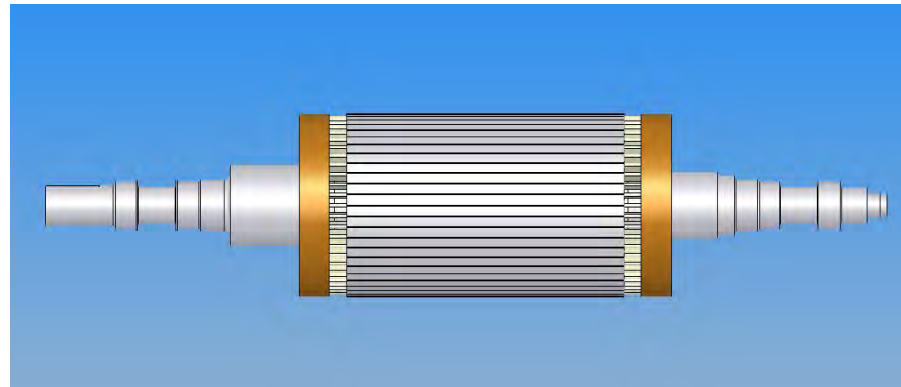
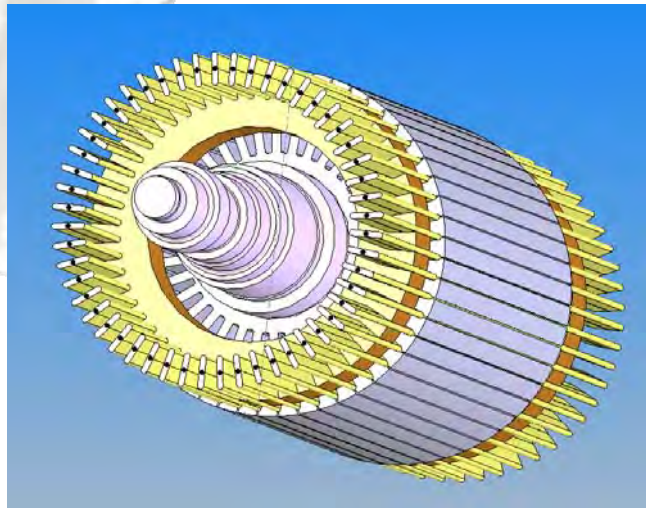





## MANAGEMENT

### Experienced management team with a history of bringing technology to market and driving growth

**Timothy Hassett**  
CEO, Chairman & Co-  
Founder

- 30+ years experience managing and growing manufacturing firms: GE, WaveCrest, Hawk Motors, Rockwell Automation
- Turned around two divisions(Distribution Services & Motors) for Jack Welch at GE
  - Took WaveCrest from \$0 to \$30M in revenues in 18 months (with Mark) with 3 NPI platforms
  - Took Lemo from \$32 to \$75M in revenue and grew net income 22x in 4 years (with Mark)
  - Mars Rover drive train co-designer

**Mark Hodowanec**  
Co-Founder

- 25+ years of engineering & operations expertise: more than 30 publications & numerous patents
- Engineering Director at Curtiss-Wright
  - Led new product innovation at Reliance Electric
  - Engineering Manager at Siemens Energy and Automation
  - Led Emerson to API 541, 610 Rev. III&IV approvals – after Emerson’s efforts had failed for 11 years
  - Mars Rover drive train co-designer

**Theodore Banzhaf**  
President

- 20+ years experience in growing public companies in all facets of finance, growth strategies, and management
- Expertise in maximization of shareholder value and maturing small companies into larger organizations
  - SpatiaLight Technologies (NASDAQ:HDTV), CE Unterburg Towbin, Raymond James

**Quentin Ponder**  
Vice Chairman

- 50+ years experience in management: President Baldor Electric Motors CEO, Franklin Electric Motors, GE
- Noted in the book “World Class Manufacturing: The Next Decade” as one of the 5 best executives for manufacturing improvement pathways in the modern industrial era
  - Coined the term “Flex Flow Manufacturing” based on his revolutionary manufacturing management techniques



## BOARD OF DIRECTORS / ADVISORS

- **William Finley**
  - **CTO, Siemens Energy & Automation.** (current)
- **Richard Schul – Director**
  - **President of Motors & Generator & SVP, Emerson Electric,** (former) 43 year motor/generator veteran, industry icon. Emerson - largest generator manufacturer in the world.
- **Dan Ustian – Director**
  - **Chairman & CEO of Navistar, Inc.** (former), 37 years in the auto industry
- **Scott Van Dorn**
  - **Engineering Director at Navistar** and former **Chief Engineer, Ford** (F-series trucks)
- **Roman Kuropas –**
  - **Founder and CEO of Inverom & GE Plastics Exec.,** designer and user interface electronics for Tesla, Lamborghini, Ferrari, Maserati and Fisker
- **Donald L. Bowman- Director**
  - **CEO of BVU** (Formerly known as Bristol Virginia Utilities).
- **Chris McKee - Director**
  - **General Counsel & SVP Business Dev., GTT Communications, Inc.** (NYSE:GTT)



## MARKET DRILL DOWN: MOTORS/GENERATORS

Cool Tech has designed and patented a passive technology that removes heat equivalent to liquid cooling in a totally enclosed enclosure...

A VERY appealing ROI story for OEM customers

- Augmenting and replacing current cooling methods of electric motors and generators with physics
- Improves power density by 25 to 40%
  - 1000 hp motor can go up to 1400 hp; 40%( Equivalent Liquid cooling result)
- Reduces manufacturing costs up to 30%
- All but eliminates maintenance costs
- Tremendous size and cost edge over competition

*“This industry has been scraping to save pennies for years and Cool Tech is giving it \$20 bills.”*

*Richard Schul – former President of Motors & Generators, SVP Emerson Electric Corporation*



## MARKET DRILL DOWN: MOTORS/GENERATORS

**These sections  
are the Heat  
Exchanger**

**Cool Technology  
removes the need  
for the Heat  
Exchanger – it's  
that simple.**

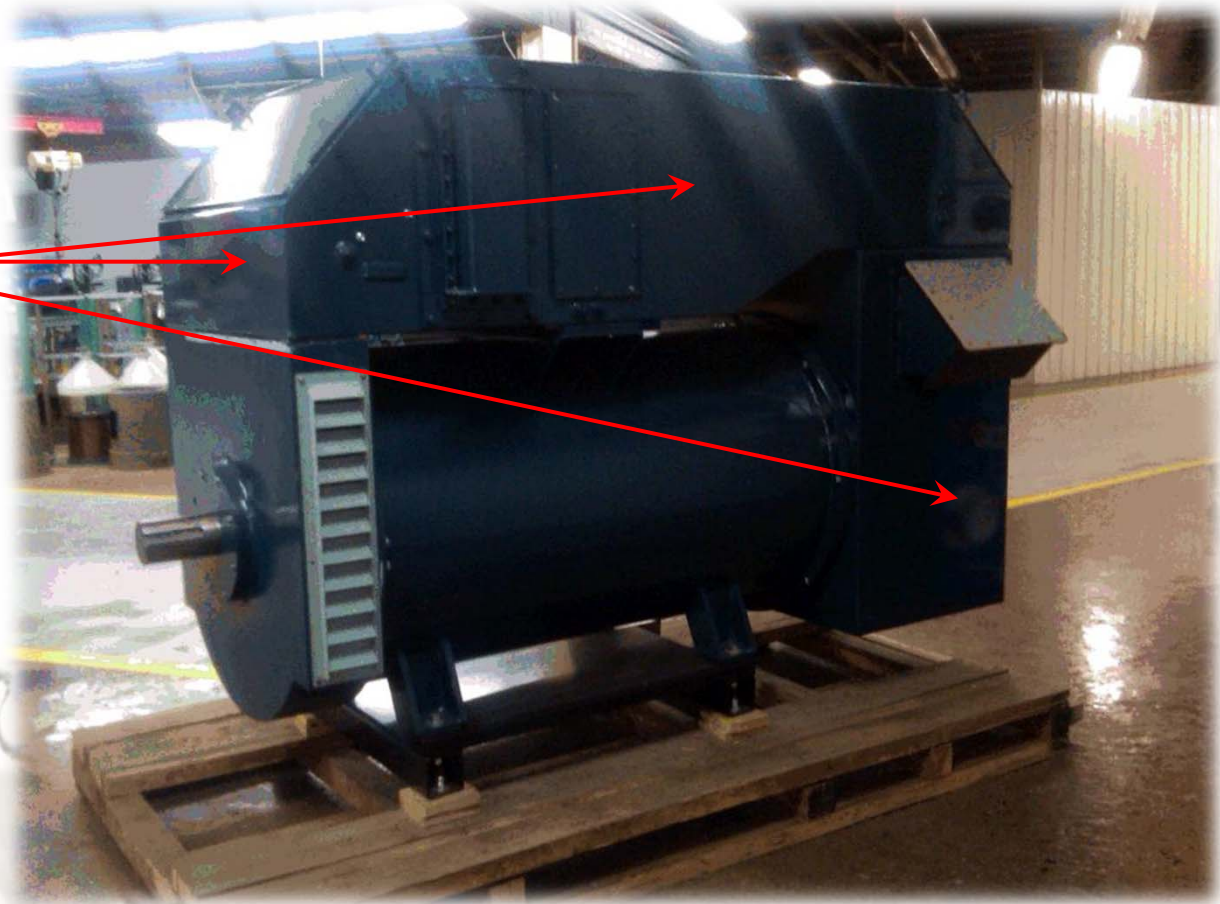





## MARKET DRILL DOWN: MOTORS/GENERATORS

- **First COST OUT in the Motors/Generators industry of over 5% in 50 years**
  - The best cooling available at the lowest cost
- **Cool Tech's go-to-market strategy: Phase 1 and Phase 2**

### Phase 1 Implementation (Machine External/Retrofit)

- Simple redesign of the heat exchanger
- ~25% power density improvement

### Picture to the right: Emerson LS 625KW

- Industry leader OEM testing
  - 625 Kilowatt Generator
  - Put out more than 800 kilowatts after Cool Tech's cooling technology was added (in the yellow hood)





## MARKET DRILL DOWN: MOTORS/GENERATORS

Phase 2 Implementation (Machine Internal)

Cool Tech Radial Vent Heat Pipe goes right into the core (Stator and Rotor) of the motor/generator to replace the need for a heat exchanger entirely. Up to 40% increase in power density.



### Electric Motor – Compelling OEM Manufacturer

#### Benefits Model

	Air Cooled Motor	Cool Tech Improved Motor	Improvement
<b>Output (Horsepower)</b>	1000 hp	1400 hp	
<b>Retail Price</b>	\$100,000	\$100,000	
<b>COGS</b>	\$50,000	\$35,000	30%
<b>Gross Profit</b>	\$50,000	\$65,000	30%



## MARKET DRILL DOWN: PUMPS (Water & Wastewater)

ESSCO Pumps and Controls, industry leader since 1955

*“...This solves one of our industry’s Achilles’ heels. **this dramatically reduce maintenance costs and time loss while improving pump output and flow as well. It’s a real game changer.**”* – John Ivins, President of ESSCO

- Targeted for California & New York initially
- New method of cooling the drive motors
  - Removes huge maintenance costs for end user
  - More than doubles horsepower output (OEM partner is Nidec)
- Picture to the right
  - ESSCO testing of Cool Tech a huge success





## MARKET DRILL DOWN: MOTORS/GEN/PUMPS (Target Customers)

Management has relationships with nearly all the major industry players.

The “Big-8” control approximately 80-85% of the m/g market

~\$150b Addressable M/G Market



SIEMENS

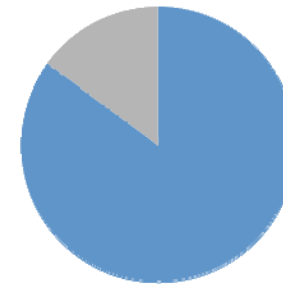

Aftermarket – Royal Dutch, Chevron, ExxonMobil, BP, etc.

- We estimate the water and wastewater market in the United States to be ~\$30 billion annually.
- Being commercialized by ESSCO & Reliable Electric Motor Company





## MARKET DRILL DOWN: MOBILE GENERATION (MG)

**Power Onboard transforms any truck into a mobile generator.  
No more need to pull a trailer**

- Either new or existing trucks: Class 2 to class 8
  - Does not affect truck warranties: Moss/Warren Act.
- 20% of the weight and much lower cost than tow-behind generators
- Uses the truck's engine to deliver up to **400 kW of electric power**
- To run compressors, welders, backup power or plug into the smart grid
- On board telematics (diagnostics) and integrated dashboard control (real time predictive and preventative maintenance capability)
- Any type of engine or fuel type (natural gas, diesel, gas, fuel cell, Solar)



## MARKET DRILL DOWN: MOBILE GENERATION (MG)

### Green Proposition

- Lower emissions, less fuel
- No idle feature
  - Runs completely on CNG w/ no emissions, less fuel
- PPIG & unitized generator system, less energy same power, less fuel
- Fuel agnostic, CNG, LNG, Electric, Fuel Cell, Gas, Diesel, Solar
- No Lithium Ion Batteries, BUT we can use them or Lead Acid (99% recyclable)



## MARKET DRILL DOWN: MOBILE GENERATION (MG)

- **Worldwide market in excess of \$100 billion**

**Disaster Response**

**Developing Markets**

**Utility Fleets**

- Class 2-8 trucks tow gensets to the jobsite – we put it up under the chassis

**vs. Tow-Behind Generators**

- 20 to 30% of the weight
- 20 to 40% lower cost
- Chassis mount under the vehicle
- Huge fuel savings (typical work truck \$3K-\$8K annual savings)
- No warranty issues
- Mobile power capabilities – up to 400 kW.

***Example: Doosan G70 4800 lbs – Cool Tech:1028 lbs***



## CONTACT INFORMATION

**OTCQB: WARM**

**Thank You**

for your interest

Timothy J. Hassett  
Chairman and CEO

[thassett@cooltechnologiesinc.com](mailto:thassett@cooltechnologiesinc.com)





## FORWARD LOOKING STATEMENTS

This presentation contains information that is “forward-looking” in that it describes events and conditions Cool Technologies, Inc. reasonably expects to occur in the future. Expectations for the future performance of Cool Technologies, Inc. are dependent upon a number of factors, and there can be no assurance that Cool Technologies, Inc. will achieve the results as contemplated herein. Certain statements contained in this release using the terms “will”, “could”, “may”, “expects to”, “potential”, “planned”, “expected”, “estimates”, “schedule”, “anticipates”, and other terms denoting future possibilities, are forward-looking statements within the meaning of the Private Securities Litigation Reform Act of 1995. The accuracy of these statements cannot be guaranteed as they are subject to a variety of risks, which are beyond Cool Technologies, Inc.’s ability to predict, or control and which may cause actual results to differ materially from the estimates contained herein. Among these risks are those set forth in Cool Technologies, Inc.’s Form 10-K and in reports subsequently filed with the Securities and Exchange Commission, and in addition to the other risks and caveats included in this presentation. It is important that each person reviewing this presentation understand the significant risks attendant to the operations of Cool Technologies, Inc. Except as required by law, Cool Technologies, Inc. disclaims any obligation to update any forward-looking statement contained herein.